

HIGH VOLUME LOW SPEED FANS



IND61-3PH / IND73-3PH

FEATURES

- 5 patented aluminum blades (mill finish).
- Powerful winglets that eliminates wind noise.
- Lenze Gearmotor custom IEZ efficient helical-cut gears for efficient, durable, and reliable operation. Lubricated for life. IP 55.
- Hub System - Machine cut, precision components for uniform load distribution.
- Mounting options - I-beam or concrete mounting.
- Safety components include, airfoil retainers, hub retainer clips, safety cables, & grade 8 bolts.

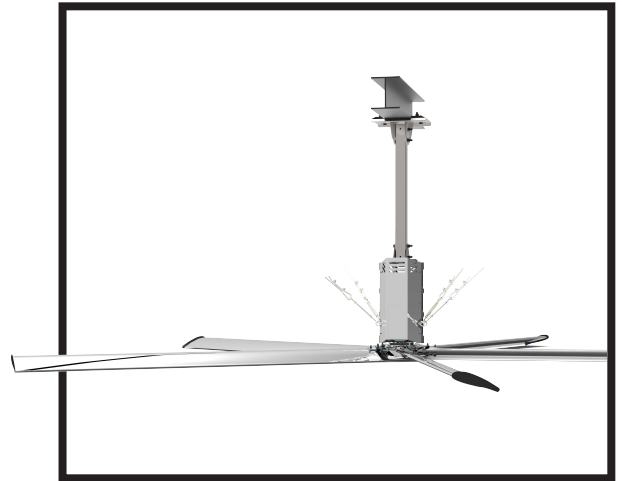

INSTALLATIONS

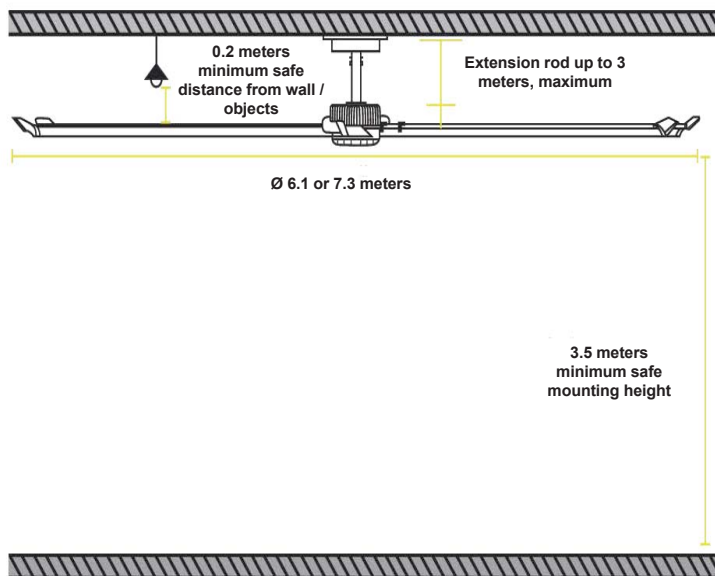

ACCESSORIES



Controller

- Rittal Control Panel
- Schneider Breaker
- Danfoss VFD
- 50m cable



Winglet

MOUNTING OPTIONS



I-Beam



Concrete

TECHNICAL SPECIFICATIONS

MODEL	Ø SIZE	# of Blade / Airfoil	RPM	CAPACITY (CMM)	WATTS	VOLTS / Hz
IND61-3PH	6.1m (20 ft.)	5 blades	65	12,150	1.5 kW	380-440V 60Hz 3 Ph
IND73-3PH	7.3m (24 ft.)	5 blades	55	13,050	1.5 kW	380-440V 60Hz 3 Ph